



JMC RECYCLING SYSTEMS

For all your metal recycling needs

The Manta 54 Automatic Baler



- Bale at an average rate of 20 bales per hour
- Fully Automatic
- Remote Control Available
- Available as a Roll on Roll off or Static Baler
- Diesel or Electric Powered

The New Manta 54 Baler is a compact, mobile baler perfect for aluminium, copper and light steel into manageable size bales of approx. 500x450mm.



Easy to use - The two wings of the baler open out fully to allow the material to be fed in from both sides, speeding up the loading process. A bale out put door comes as standard for quick release of the bale.

Long Lasting - With hardox wear plates fitted in the bale box, this baler won't crack under the pressure.

JMC Recycling Systems Ltd

Unit 2, Harrimans Lane, Dunkirk, Nottingham. England NG7 2SD
Tel: +44 (0)115 9409630, Fax: +44 (0)115 9791478
email: info@jmcrecycling.com web site: www.jmcrecycling.com



JMC RECYCLING SYSTEMS

For all your metal recycling needs

The Manta 54 Automatic Baler

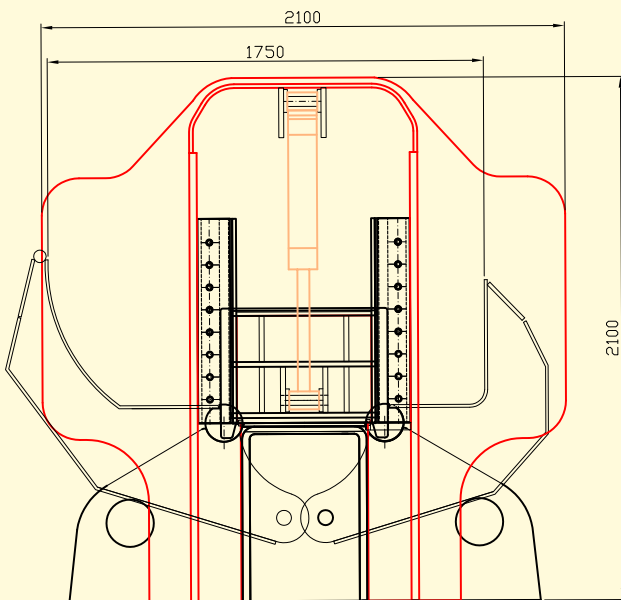
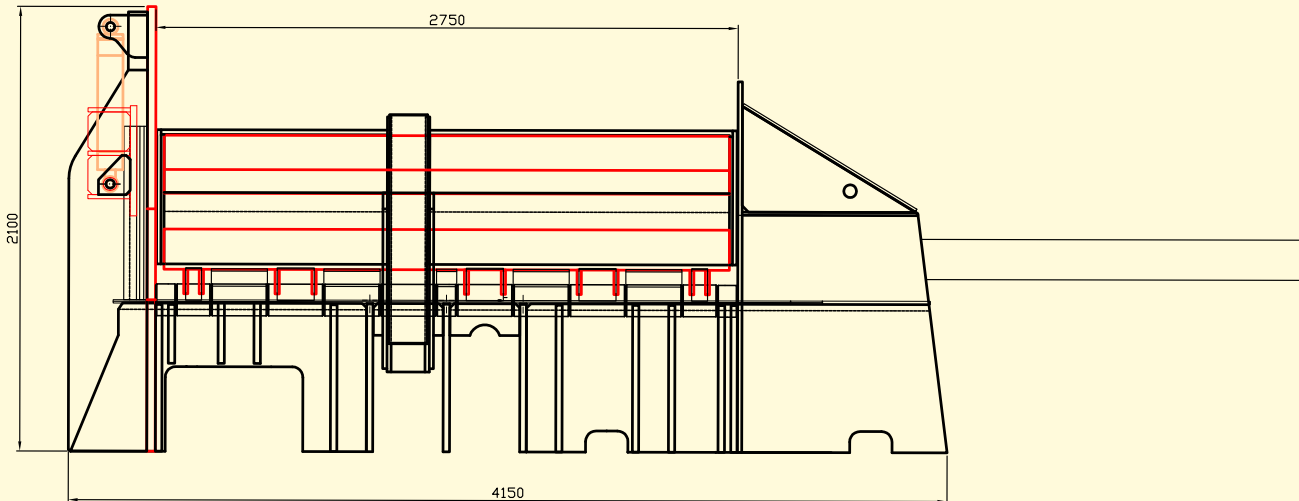

Technical Data

Engine:	4-Stroke Diesel 83 HP / 55 kW
Pump:	Variable output Kawasaki pump 1 gear pump
Hydraulic Oil:	Approx 400 lt
Cooling:	Radiator for oil cooling on the oil return to the tank
Dimensions:	
Bale Size:	500x450mm
Overall Length:	5500mm
Width:	1750mm
Box Length:	2750mm
Weight:	15,000kg#(this model only)
Optional Extras:	Can be supplied as Electric or Diesel

JMC Recycling Systems Ltd

Unit 2, Harrimans Lane, Dunkirk, Nottingham. England NG7 2SD

Tel: +44 (0)115 9409630, Fax: +44 (0)115 9791478

email: info@jmcrecycling.com web site: www.jmcrecycling.com